



Please read this Manual carefully before installing and using the product .

# JK-A52E Input Module

## 1 Product overview

- 1.1** JK-A52E Input Module (after this referred to as JK-A52E Module) is used with the fire linkage controller. It can be connected to JTY-GD-A30KE point-type photoelectric smoke fire detector, JTW-ZD-A20KE point-type heat fire detector, J-SAP-M-A62KE manual call point and J-SAP-M-A63KE fire hydrant button. After these devices are operated, the output alarm signal is transmitted to the controller by the JK-A52E module via the signal bus, and the alarm is generated.

## 2 Technical parameters

### 2.1

Items	Parameters
Executive standard	GB 16806-2006
Working mode	Four-wire system
Operating voltage	DC 24V
Static current	< 0.5mA (bus); < 15mA (Power cord)
Operating current	< 2mA (bus); < 35mA (Power cord)
Normal indication	The inspection status indicator blinks once every 12 seconds. The action status indicator is steady on
weight	Approx. 110g (with base)
Overall dimension	86×86×35(mm) (with base)
Use environment	Temperature: -10°C ~ 50°C; Relative humidity: ≤95% (40°C±2°C no condensation)
Coding mode	Through the encoder can be field coding, address coding 1 ~ 324 optional

## 3 Appearance and dimensions

### 3.1

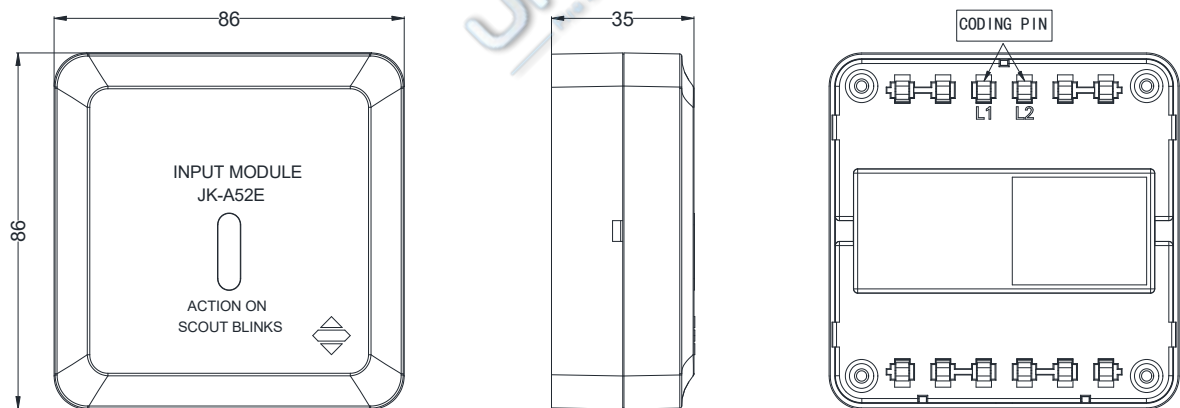

Figure 1 Main body of JK-A52E module (Unit: mm)

## 4 Use and engineering application

### 4.1 Installation base (DZ-A52)

DZ-A52 terminal definition:

D1	DC24V access terminal (regardless of polarity)	D2	DC24V access terminal (regardless of polarity)
L1	signal access terminal of the fire alarm control panel (regardless of polarity)	L2	signal access terminal of the fire alarm control panel (regardless of polarity)
TO+	Load access terminal (positive)	T0-	Load access terminal (negative)

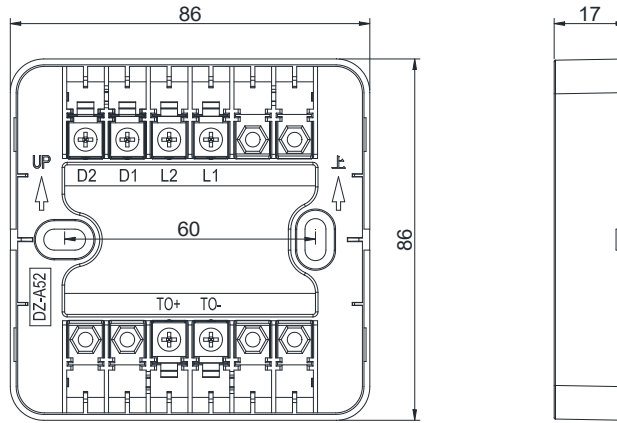

Figure2 JK-A52E Module Base(DZ-A52)

4.2 Connection mode 1: Connect the detector (as shown in Figure 3 below) :

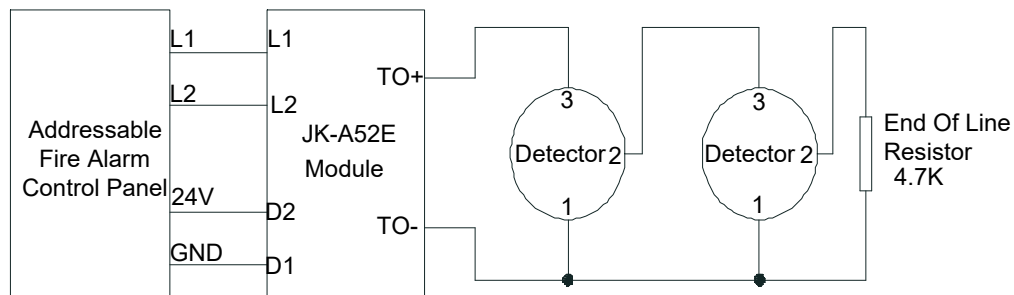

Figure 3

4.3 Connection mode 2: Connect the manual call point (or fire hydrant button)(as shown in Figure 4 below):

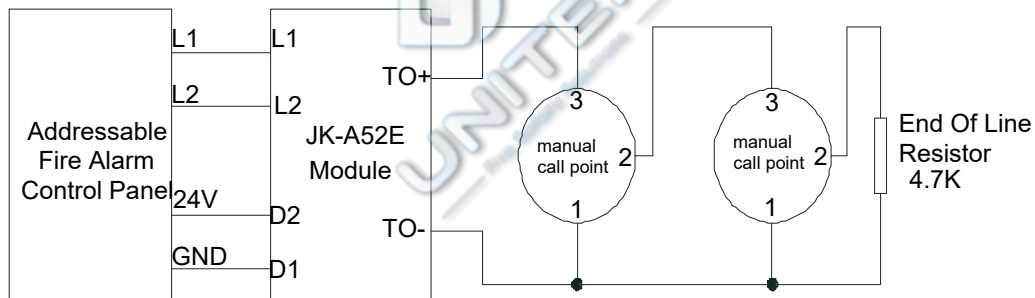

Figure 4

**Note:** 24V power supply can use DC24V provided on site; when using the JK-A52E module , it must be connected with 4.7K end of line resistor.

5 Product installation and commissioning (⚠ Warning: The module must not be installed in the power distribution (control) cabinet (box).

- 5.1 Make sure the type of the module matches the type given on the construction drawings;
- 5.2 Clamp the output end of the encoder to the rear cover L1 and L2 (regardless of polarity) as shown in Figure 1, set the encoder to the encoding function, and set the correct address, press the execute key to complete the address encoding;
- 5.3 Wire correctly as shown in Figure 3 or Figure 4;
- 5.4 According to the construction drawings, use two M4 screws to secure the base of the module through the two oval screw holes shown in Figure 2, and then insert the main body of the module into the base of the module. Ensure that the two are in good contact.
- 5.5 After all modules are installed and confirmed, power on the fire control linkage controller. After the automatic login is



successful, the module inspection indicator blinks once every 12 seconds, indicating that the module is working.

- 5.6 After the installation, debug the device connected to the module to generate action signals, or simulate the device' s action signals, the module can transmit the action signals to the controller, and light its own indicator, indicating that the module is operating normally;
- 5.7 After commissioning, reset the module and related devices using the fire linkage control panel.

## 6 Matters needing attention ⚠

- 6.1 When the JK-A52E module is connected to the manual alarm button and the fire hydrant button, pay attention to the positive and negative poles are not be reversed;
- 6.2 The JK-A52E module can connect up to 25 detectors in parallel, but only 1 detector can alarm at the same time. If multiple detectors alarm at the same time, the detector will not display the alarm status correctly due to the insufficient brightness of the detector indicator light;
- 6.3 In the same loop, it is not allowed to access two or more products with the same address, otherwise the system will report a double code fault;
- 6.4 Please confirm whether the external device connected to the module belongs to the feedback type or the fire alarm type, and set the corresponding type of the device type of the module in the control panel .



 SHENZHEN HTI SANJIANG ELECTRONICS CO., LTD.

Address: 3F, Guangcai Xintiandi Mansion, Nanshan Road, Nanshan District, Shenzhen, Guangdong, 518054, China

Tel: +86(755)86226969

Fax: +86(755)86223939

Website: <http://www.sanjiang-security.com>