



# Extinguishing technology VSN 1230/200 P21.231.240 - 1

## Cylinder rack VSN 1230/200

### Clamp for extinguishing agent cylinder VSN 1230/200



#### Approvals

(VdS approval is not required!)



1) Listed system covered by UL-file EX26532 (Ar, VSN 200 and VSN 1230)

2) Part of the system approval

#### SAP designation

e.g. part no. 887628: Clamp for ext. agent cylinder 25/50/52/80l VSN200

#### Maintenance

maintenance-free

Designation	Part no.	Steel cylinder	Weight kg (lbs)	
Clamp for extinguishing agent cylinder VSN 1230/200	25/50/52/80l	887628	25 l, 50 l, 52 l, 80 l (ø267)	1.46 (3.2)
	22/40l drawn	888014	22 l, 40 l	1.26 (2.8)
	100l drawn	887988	100 l	1.69 (3.7)
	140l drawn	887638	140 l (ø356)	1.87 (4.1)
	80/140/180l drawn/welded	887639	80 l, 106 l, 140 l, 147 l, 180 l	2.08 (4.6)

#### Technical data

Material .....steel strip EN 10048 - 4,0 x 60, S235JR  
 Finish .....matt-finished or powder-coated  
 .....RAL 9011 graphite black

#### Not included in delivery

Fastening material

#### Dimension drawing

Dimensions in mm (inch)

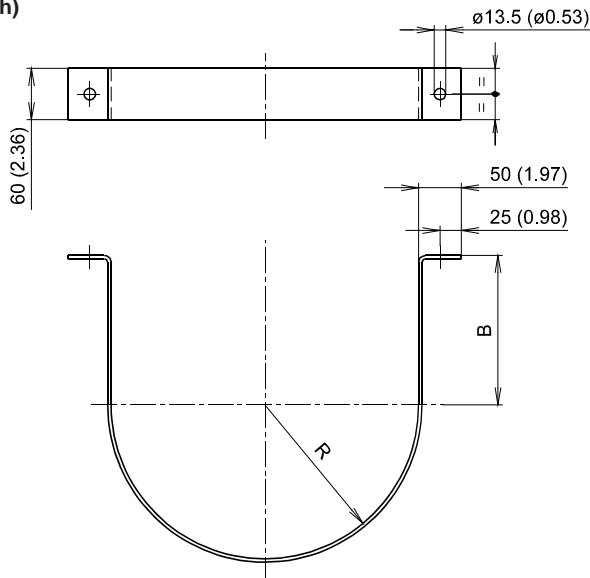

Clamp for exting. agent cylinder	R	B
25/50/52/80l	134 (5.28)	120 (4.72)
22/40l drawn	117 (4.60)	112 (4.41)
100l drawn	160 (6.30)	155 (6.10)
140l drawn	180 (7.09)	175 (6.89)
80/140/180l drawn/welded	205 (8.07)	200 (7.87)

Ä01 / 2015-01  
The contents of this publication are subject to modifications without notice. All rights reserved.